



**SPECIAL APPLICATION GAUGES**

# Series P-600 Welding and Compressed Gas Gauges

**DESCRIPTION**

AMETEK U.S. Gauge offers a wide variety of welding and compressed gas gauges used on various types of regulators. The high pressure gauges are used for measuring cylinder or tank pressure. The low pressure gauges are used on the downstream side of the regulator to indicate regulated, reduced pressure.

The low pressure gauges (15-1000 psi) are UL 252A recognized. High pressure gauges (1500-6000 psi) are UL 404 listed. Cleanliness for all gauges is in accordance with Level IV of ASME B40.100-2005.

U.S. Gauge compressed gas gauges are available in 1-1/2", 50mm, 2", and 2-1/2" sizes with polished brass or gold painted steel standard. Gauges are also available with chrome plated steel cases and chrome plated brass sockets for medical gas applications.

ISO5171 compliance, custom sizes, dials and finishes are available for OEM customers.

**SPECIFICATIONS**

**SIZES:** 1-1/2", 50mm, 2", and 2-1/2"

**RANGES:**

*High Pressure* – (Models P-601, P-607, or P-697) 1500 psi, 2000 psi, 3000 psi, and 4000 psi (P-697 only available in 4000 psi)

*Low Pressure* – (Models P-612, P-618, or P-698) 15 psi, 30 psi, 60 psi, 100 psi, 160 psi, 200 psi, 400 psi, 600 psi (2" and 2-1/2" version only), and 1000 psi (2" and 2-1/2" version only)

*UL High Pressure* – (Models P-601, P-607, or P-697) UL 404 listed (only 4000 psi for 50mm gauge P-697)

*Low Pressure* – (2" and 2-1/2" Models P-612, P-618) 30 psi, 60 psi, and 100 psi UL 252A Class V recognized; 160 psi UL 252A Class VI recognized; 200 psi, 400 psi, 600 psi, and 1000 psi UL 252A Class VII recognized\*. For 50mm 30 psi UL 252A Class III, 60 psi and 100 psi Class V, and 400 psi Class VII.

**ACCURACY:** ±3-2-3% of span (Grade B)

**BOURDON TUBE:**

*High Pressure* – (Models P-601, P-607, or P-697) Phosphor bronze, silver soldered

*Low Pressure* – (Models P-612, P-618, or P-698) 15 psi beryllium copper, 30 psi to 1000 psi phosphor bronze

**WINDOW:** One-piece polycarbonate

**MOVEMENT:** Brass

**DIAL:** Galvalume, white background with black markings  
Major graduations and "USE NO OIL" in red

Custom dials and dual scales available with minimum order quantity and dial set-up charge

**POINTER:** Galvalume aluminum, black finish

**CASE:** Polished brass or brass painted steel – chrome plated steel cases available in minimum order quantities.

**MODELS 1-1/2", 2", and 2-1/2"**

P-601 – Brass case, high pressure

P-612 – Brass case, low pressure

P-607 – Steel case, high pressure

P-609 – Brass plated steel case, high pressure

P-610 – Brass plated steel case, low pressure

P-618 – Steel case, low pressure

**MODELS 50mm**

P-697 – Steel case, high pressure (painted gold or black)

P-698 – Steel case, low pressure (painted gold or black)

**CONNECTION:** 1-1/2" brass 1/8-27 NPT lower mount; 2" and 2-1/2" brass 1/4-18 NPT lower mount

Center back mount also available, subject to minimum order quantity

\* (1-1/2" Models P-612 and P-618) - 30, 60 and 100 psi UL252A Class V recognized; 160 and 200 psi Class VI recognized; 300 and 400 psi UL252A Class VII recognized

(50mm Model-698) - 30 psi; UL252A Class III; 60 psi and 100 psi UL252A Class V; and 400 psi UL252A Class VIII

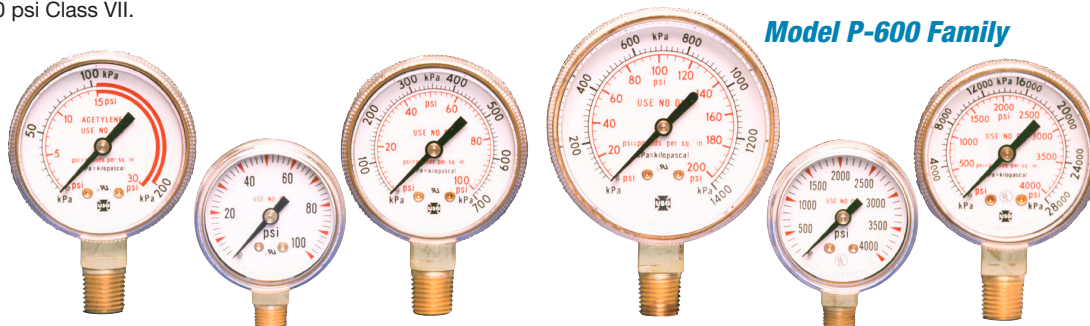

**Model P-600 Family**



**SPECIAL APPLICATION GAUGES**

# Series P-600 Welding and Compressed Gas Gauges

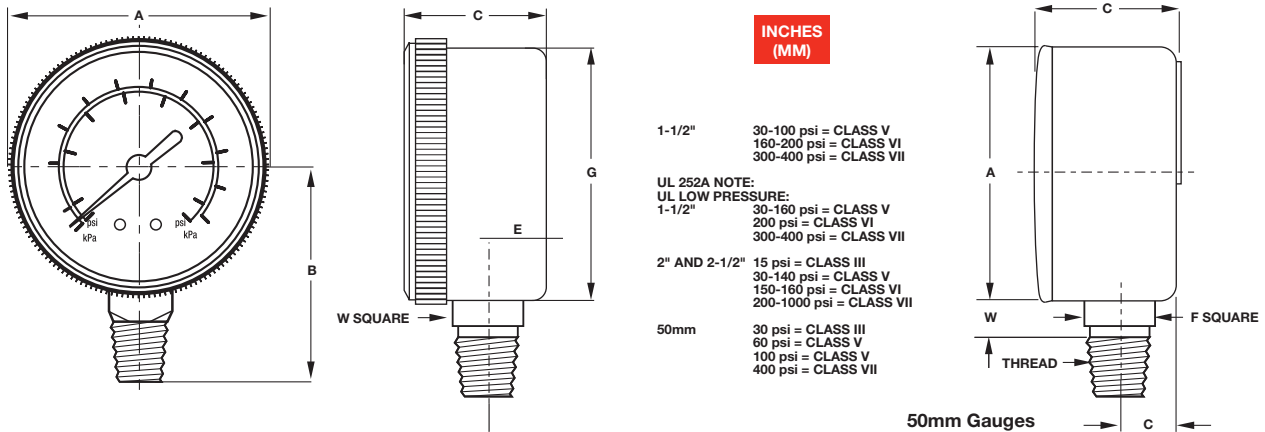

**Dimensions**

Model	Dial Size	Case	Style	Unit	A	B	C	E	G	W
P-601	1-1/2" Lower Mount	Brass Polished or Steel	1	inches mm	1.78 45.2	1.40 35.6	0.91 23.1	0.34 8.6	1.63 41.4	0.43 10.9
P-607	1-1/2" Center Back Mount		1	inches mm	1.78 45.2	- -	0.92 23.4	- -	1.63 41.4	0.44 11.2
P-612	2" Lower Mount		1	inches mm	2.26 57.4	1.95 49.5	1.13 28.7	0.43 10.9	2.05 52.1	0.55 14.0
P-618	2-1/2" Lower Mount		1	inches mm	2.85 72.4	2.33 59.2	1.22 31.0	0.45 11.4	2.67 67.8	0.55 14.0
P-697	50mm	Steel Painted	2	inches mm	1.92 48.8	1.16 29.5	1.16 29.5	0.40 10.2	0.25 6.4	0.25 6.4
P-698			2	inches mm	1.92 48.8	1.16 29.5	1.16 29.5	0.40 10.2	0.25 6.4	0.25 6.4



**SPECIAL APPLICATION GAUGES**

# Series P-600 Welding and Compressed Gas Gauges

Spec Number Selection Chart				
Model	Ranges**	1-1/2" Spec No.	2" Spec No.	2-1/2" Spec No.
P-612	0-15 psi	–	–	50665A
	0-30 psi	166692A	165509A	165616A
	0-30 psi*	166691A	165507A	165614A
	0-60 psi	–	165567A	165660A
	0-100 psi	166359A	164257A	164285A
	0-200 psi	166361A	164259A	164287A
	0-400 psi	166364A	164261A	164289A
	0-500 psi	–	–	165064A
	0-600 psi	146474A	164262A	164290A
P-601	0-3000 psi	146451A	144202A	144203A
	0-4000 psi	146454A	143403A	143404A

\* Red Band

\*\* Dual scale dials are available, please contact Customer Service at +1 215-293-4100

P-612 – 30 psi, 60 psi, and 100 psi UL 252A Class V recognized; 200 psi, 400 psi, 500 psi, and 600 psi UL 252A Class VII recognized; P-601 – UL404 listed

Spec Number Selection Chart				
Model	Ranges**	1-1/2" Spec No.	2" Spec No.	2-1/2" Spec No.
P-618	0-30 psi	166693A	165521A	165621A
	0-30 psi*	166685A	165522A	165620A
	0-60 psi	–	165557A	165663A
	0-100 psi	–	164677A	164956A
	0-200 psi	166532A	164264A	164292A
	0-400 psi	166365A	164816A	165055A
	0-600 psi	–	164829A	165071A
P-607	0-4000 psi	146532A	139660A	156187A

\* Red Band

\*\* Dual scale dials are available, please contact Customer Service at +1 215-293-4100

P-618 – 30 psi, 60 psi, and 100 psi UL 252A Class V recognized; 200 psi, 400 psi, and 600 psi UL 252A Class VII recognized; P-607 – UL404 listed